

OPERATING PRESSURE CHANGES ACCORDING TO CHANGE OF AMBIENT TEMP ON WATER PROOF TYPE

AMBIENT TEMP	-20°C	70°C	100°C
CHANGE OF CHARACTERISTICS	-0.2 bar -2.84 psi	+0.25 bar +3.56 psi	+0.4 bar +5.69 psi

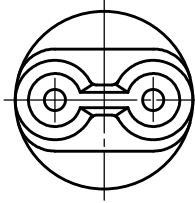

HEAT PROOF ELECTRIC VINYL WIRE  
UL1015, AWG18, 105°C (BLACK)

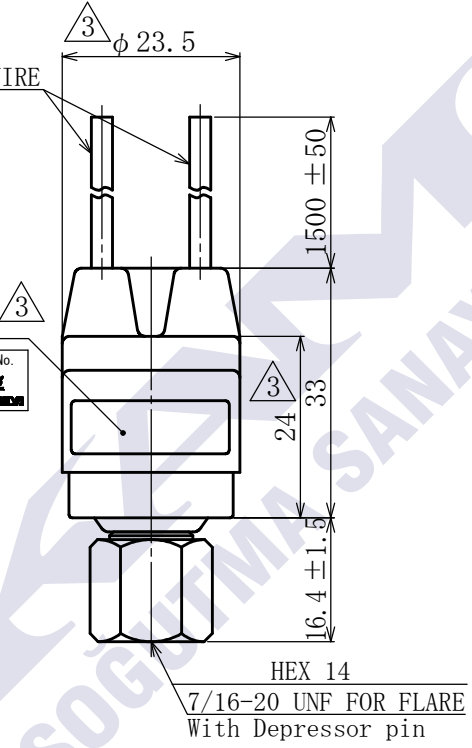
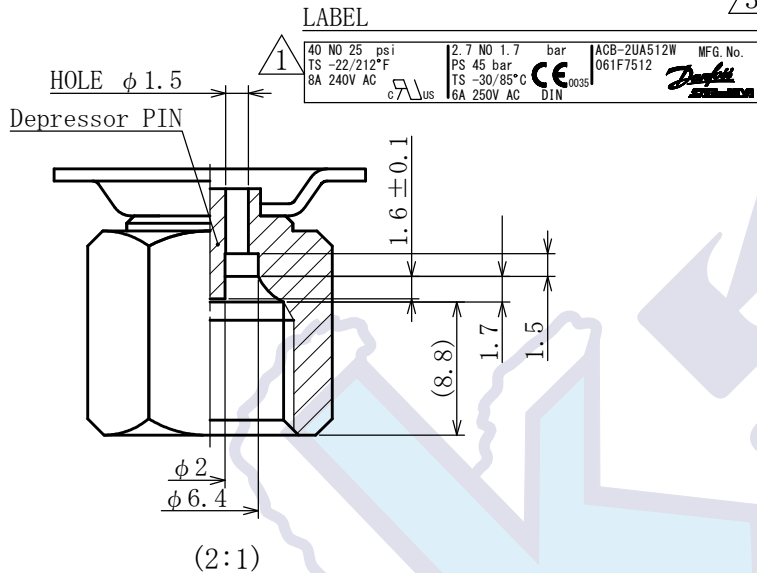

★CONFIRMATION OF DESIGN VALIDITY

We manufacture the product based on the specifications described in this drawing. Please check the safety and validity in the product design in consideration that the product is conformed to the system or not when using.

DATE	SIGN	CHANGE CONTENT
OCT. 26, 2015	3	REV. Polyamide resin material and shape
OCT. 25, 2010	2	REV. DIN Registration number
OCT 04, '04	1	REV. LABEL

ELECTRICAL OPERATING CHARACTERISTICS	OPERATING PRESS. SETTING UNIT: bar {psi}		DIFFERENTIAL
	OFF	ON	
	1.7 ± 0.5 {25 ± 7}	2.7 ± 0.5 {40 ± 7}	—
ELECTRICAL RATINGS	RATED VOLTAGE (V)		A C
	RATED AMPS. (A)		250
	INDUCTIVE AMPS.		1 ~ 6
TYPE OF CONTACT	SINGLE POLE SINGLE THROW  PRESS. RISING		
CONTACT RESISTANCE	LESS THAN 200 m OHM		
INSULATION RESISTANCE	NOT LESS THAN 100 M OHM AT DC 500V MEGGER		
DIELECTRIC STRENGTH	WITHSTAND 1500V AC FOR ONE MINUTE		
MAX. PRESSURE	35 bar {500 psi}		
AIR TIGHT PRESS.	35 bar {500 psi}		
TEST PRESS.	40 bar {580 psi}		
MAX. ALLOW. TEMP.	AMBIENT TEMP. -30 ~ 85deg. (But no freeze) FLUID TEMP. -54 ~ 135deg.		
DURABILITY	100,000 TIMES		
TÜV APPROVED	EN 12263 DIN 32733 (PSH/PSL 4B061) (4BPSh/PSL059)		
UL FILE NO. C-UL FILE NO.	E43867, E31024		

Checked by	Date	Name	TYPE CB PRESSURE SWITCH
A. K.	NOV. 20 2003		
Designed by	Scale	Catalog Number	Drawing Number
M. Y.	1:1	ACB-2UA512W	N-CB-90012-3
Drawn by	Code No. :061F 7512		
N. M.			

